

REVISIONS					
REV	ECO	DESCRIPTION	DATE	BY	APPR
A3	-	RELEASE NEW DWG FORMAT	21/OCT/13	DRP	-

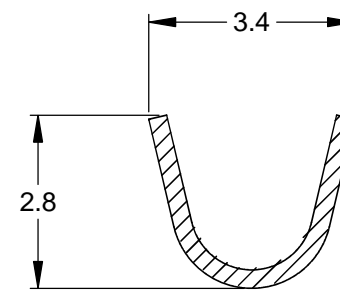

SECTION A-A
SCALE - 2:1

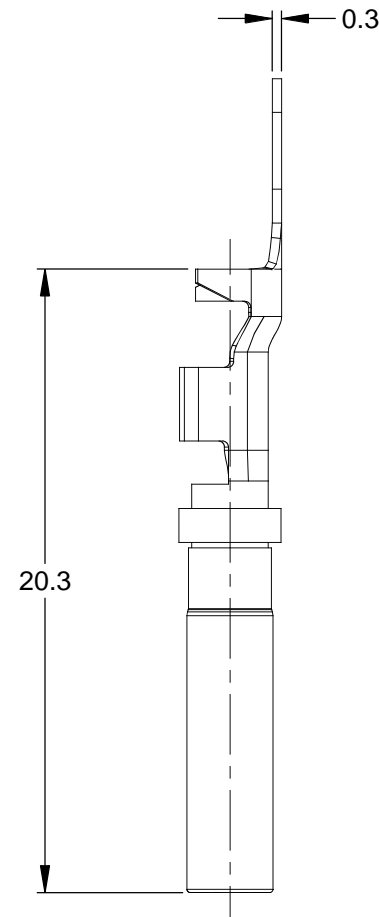
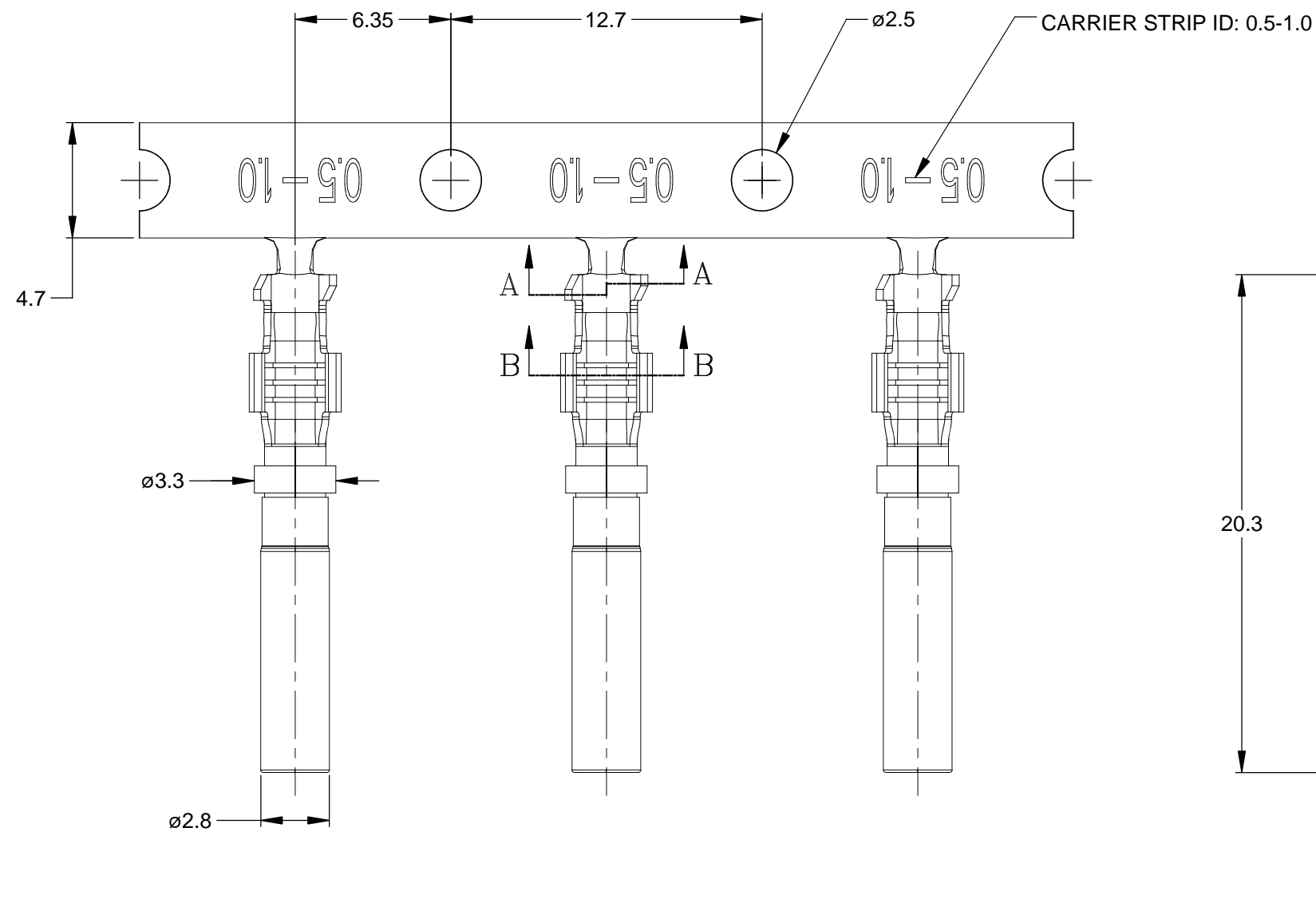
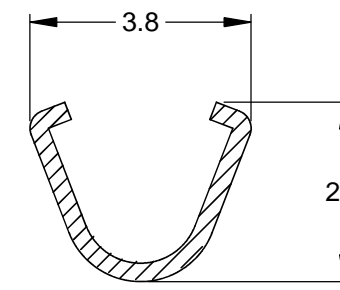

SECTION B-B
SCALE - 2:1

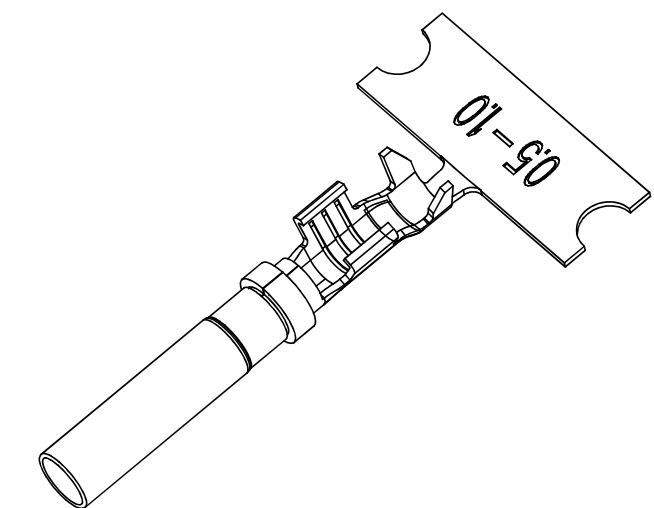

NOTES: UNLESS OTHERWISE SPECIFIED

- MATERIAL: COPPER ALLOY
- PLATING: SEE PART NUMBER CHART
- CONTACT SIZE: 16
- SPECIFICATIONS:
 - CURRENT RATING: 13 AMPS
 - CONTACT MILLIVOLT DROP: 100 MILLIVOLT DROP @ 13 AMP TEST CURRENT.
 - RoHS COMPLIANT
- RECOMMENDED WIRE RANGE: 18 - 20 AWG
- PACKAGE: 4000 PCS/REEL
- AVAILABLE APPLICATORS: MFX-3950-K OR MFX-3950-G
- ALL DIMENSIONS ARE FOR REFERENCE USE ONLY

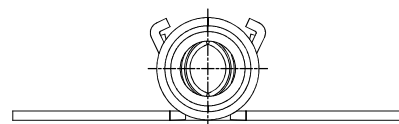

PART NUMBER CHART	
PLATING	PART NUMBERS
NICKEL	AT62-16-0622
GOLD	AT62-16-0644

SEE PART NUMBER CHART		PART NUMBER		DESCRIPTION		ITEM
QUANTITY	MATERIALS LIST					
UNLESS OTHERWISE SPECIFIED		SIGNATURES		DATE		<h1>Amphenol</h1> <p>Sine Systems - www.amphenol-sine.com 44724 Morley Drive Clinton Township, MI 48036</p> <p>CONTACT, SOCKET, STAMPED, SIZE 16, 18-20 AWG, AT & AHD-9 SERIES</p>
1) All dimensions are in metric (mm). 2) Tolerances are as follows: 1 PL DEC ±0.30 2 PL DEC ±0.15 3 PL DEC ±0.08		DRAWN: D.PARKS		21/OCT/13		
3) Note reference =		CHECKED:				
MATERIAL SPECIFICATIONS:		ENGINEER:				
PROCESS SPECIFICATIONS:		APPROVAL:				<p>THIS DRAWING IS SUPPLIED FOR INFORMATION ONLY. DESIGN FEATURES, SPECIFICATIONS AND PERFORMANCE DATA SHOWN HEREON ARE THE PROPERTY OF THE AMPHENOL CORPORATION. NO RIGHTS OF REPRODUCTION ARE IMPLIED. ALL DIMENSIONS ARE SUBJECT TO NORMAL MANUFACTURING VARIATIONS.</p>
NEXT ASSY:		CUSTOMER:				
		THIS DRAWING IS SUPPLIED FOR INFORMATION ONLY. DESIGN FEATURES, SPECIFICATIONS AND PERFORMANCE DATA SHOWN HEREON ARE THE PROPERTY OF THE AMPHENOL CORPORATION. NO RIGHTS OF REPRODUCTION ARE IMPLIED. ALL DIMENSIONS ARE SUBJECT TO NORMAL MANUFACTURING VARIATIONS.		<p>SIZE: B C- DWG NO: AT62-16-06XX REVISION: A3</p>		
		SCALE: NONE		SHEET 1 OF 1		

TITLE: SOCKET, STAMPED, SIZE 16, 18-20 AWG, AT & AHD-9 SERIES

DWG NO: AT62-16-06XX

REV: A3

SH: 1

OF: 1